

FOUR-WAY CASSETTE TYPE AIR CONDITIONER

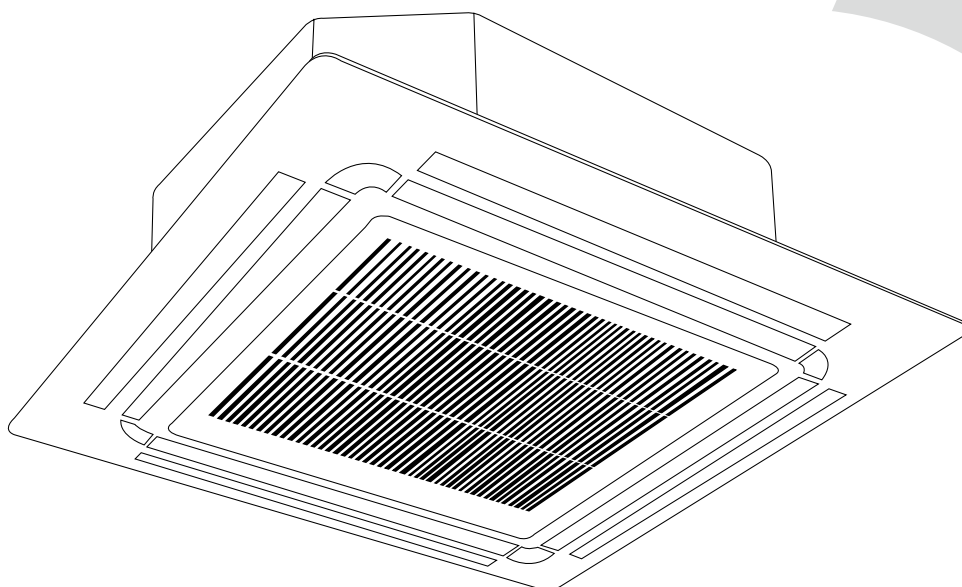

Service Manual



DXCC09E426-20

DXCC12E426-21

DXCC18E426-20

DXCC24E426-20



IMPORTANT NOTE:

Read this manual and SAFETY MANUAL(if any) carefully before installing or operating your new air conditioning unit. Make sure to save this manual for future reference.

Please check the applicable models, technical data, F-GAS(if any) and manufacturer information from the "Owner's Manual - Product Fiche " in the packaging of the outdoor unit.
(European Union products only)

Disassembly of Compact Round Flow Cassette

1. Front Panel and Display Board

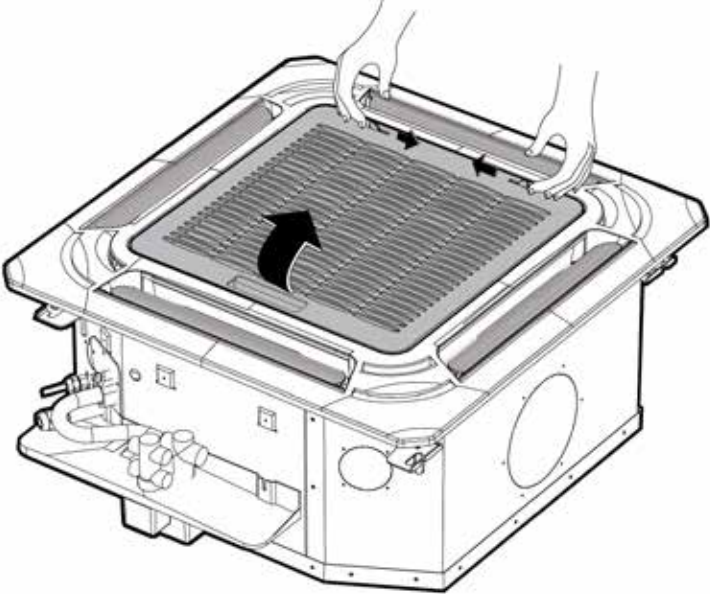
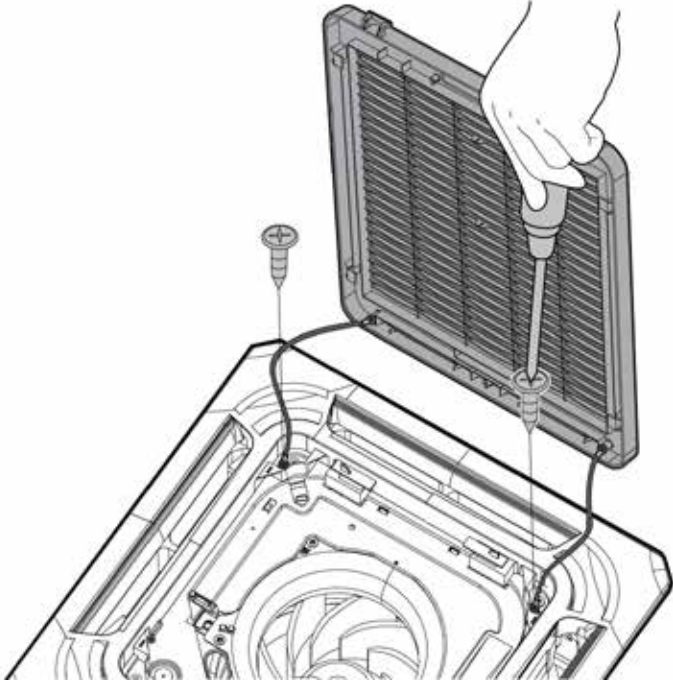
Procedure	Illustration
1) Release 2 hooks and open the panel. (see CJ_MCA_001)	 <p data-bbox="928 1048 1077 1079">CJ_MCA_001</p>
2) Remove two screws of wire line. (see CJ_MCA_002)	 <p data-bbox="928 1809 1077 1841">CJ_MCA_002</p>

Note: This section is for reference only. Actual unit appearance may vary.

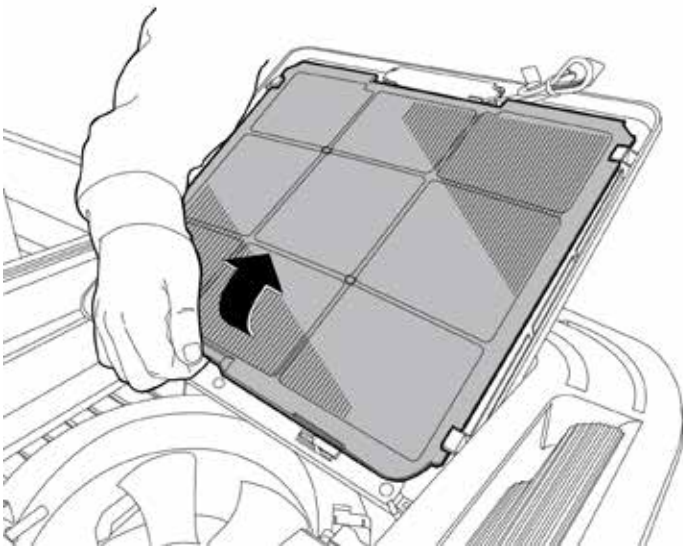
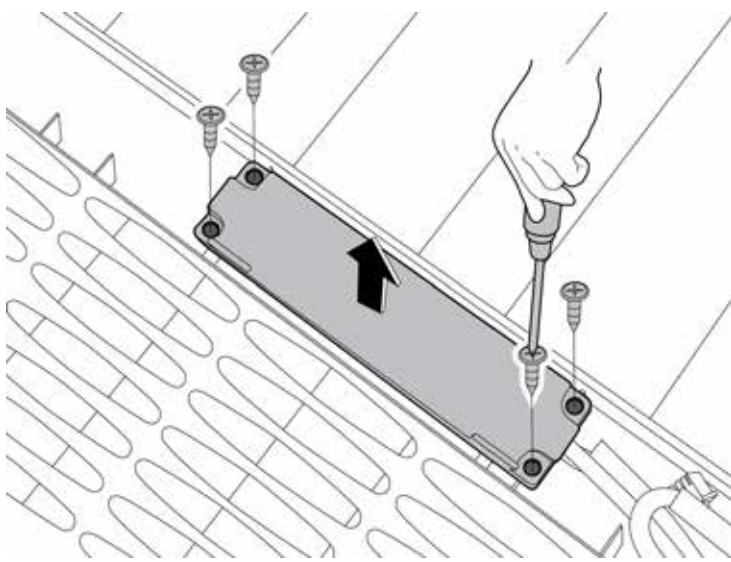
Procedure	Illustration
<p>3) Release the hook then pull up the filter(see CJ_MCA_003)</p>	 <p style="text-align: center;">CJ_MCA_00 3</p>
<p>4) Remove 4 screws of cover and remove the display board(see CJ_MCA_004)</p>	 <p style="text-align: center;">CJ_MCA_00 4</p>

Note: This section is for reference only. Actual unit appearance may vary.

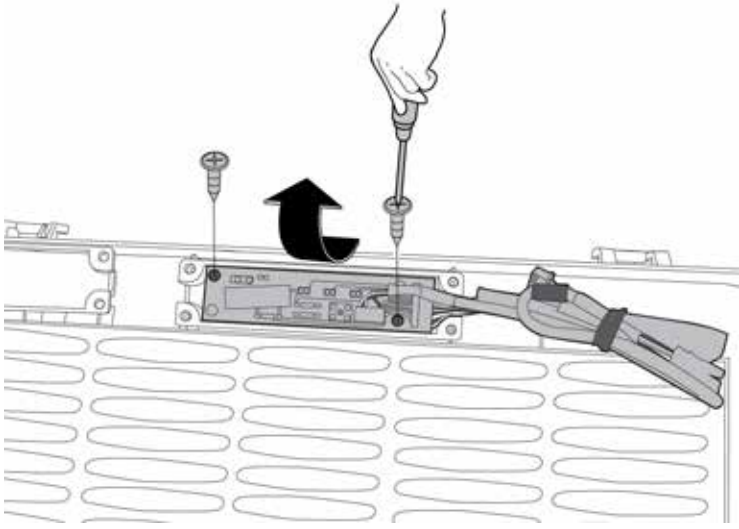
Procedure	Illustration
<p>5) Remove 2 screws of display board and remove PCB.(see CJ_MCA_00 5)</p>	 <p>CJ_MCA_00 5</p>

Note: This section is for reference only. Actual unit appearance may vary.

2. Electrical parts(Antistatic gloves must be worn.)

Note: Remove the front panel (refer to 1. Front Panel and display) before disassembling electrical parts.

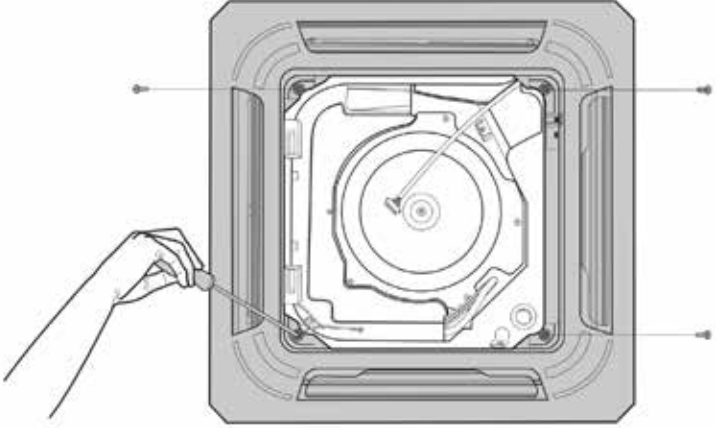
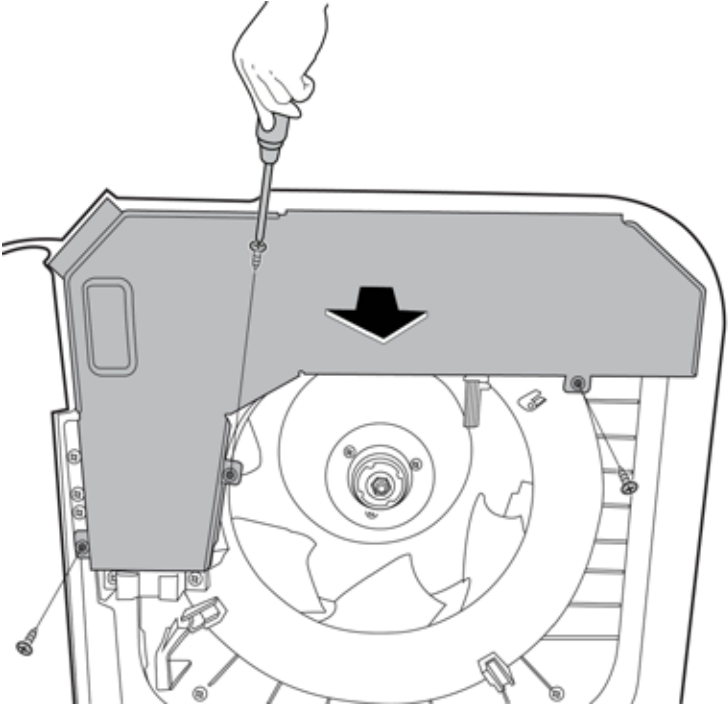
Procedure	Illustration
<p>1) Remove 4 screws of the panel and pull up the panel. (see CJ_MCA_006)</p>	 <p>CJ_MCA_00 6</p>
<p>2) Remove 3 screws of electrical cover. (see CJ_MCA_00 7)</p>	 <p>CJ_MCA_00 7</p>

Note: This section is for reference only. Actual unit appearance may vary.

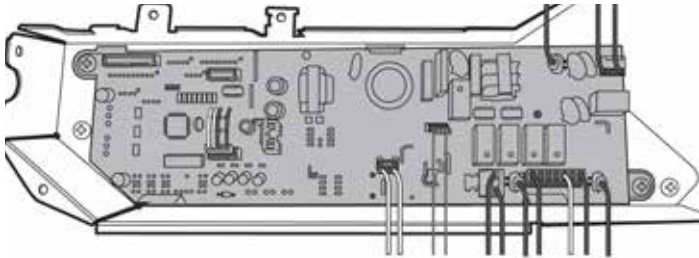
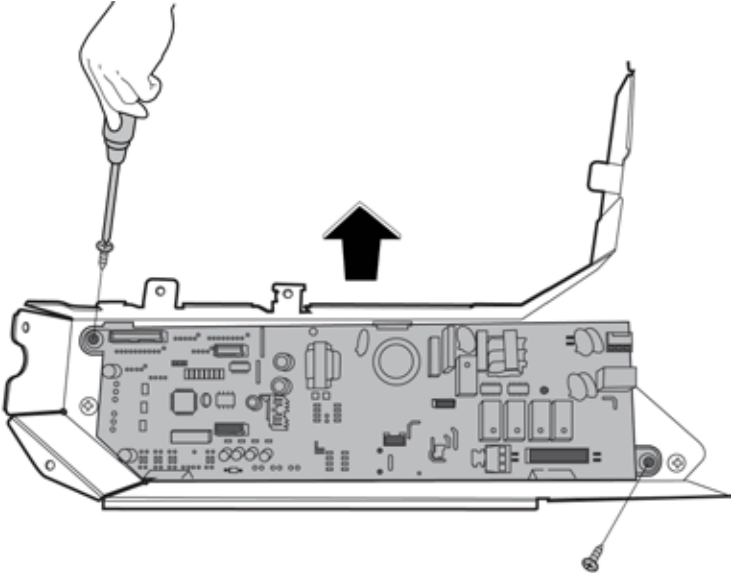
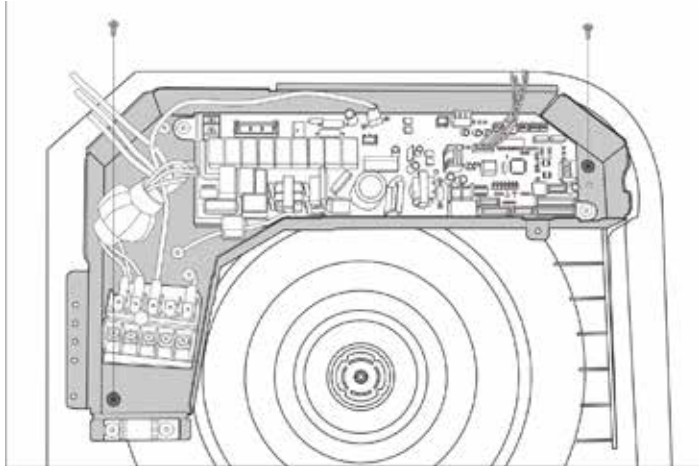
Procedure	Illustration
<p>3) Disconnect the connectors of PCB. (see CJ_MCA_00 8)</p>	 <p style="text-align: center;">CJ_MCA_00 8</p>
<p>4) Remove 2 screws of main control board and remove PCB.(see CJ_MCA_00 9)</p>	 <p style="text-align: center;">CJ_MCA_00 9</p>
<p>5) Remove 2 screws of electronic control box and remove electronic control box. (see CJ_MCA_0 10)</p>	 <p style="text-align: center;">CJ_MCA_010</p>

Note: This section is for reference only. Actual unit appearance may vary.

3. Fan motor and fan

Note: Remove the front panel and electrical parts (refer to 1 & 2) before disassembling fan motor.

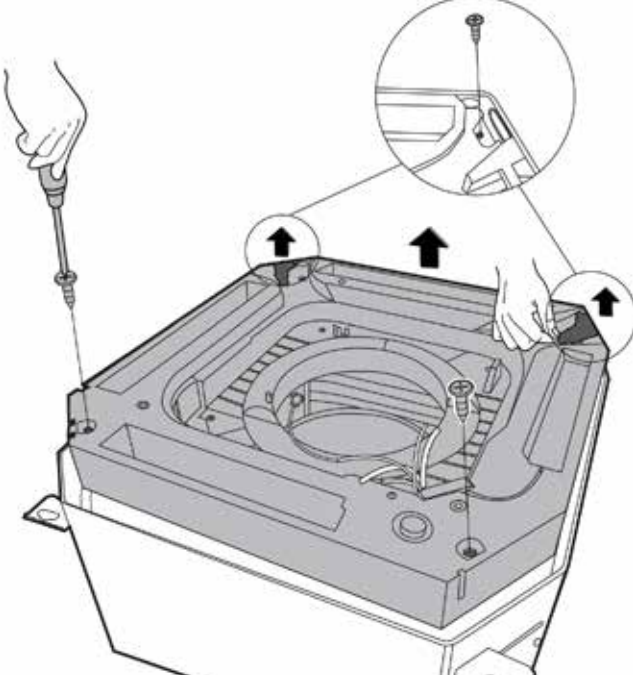
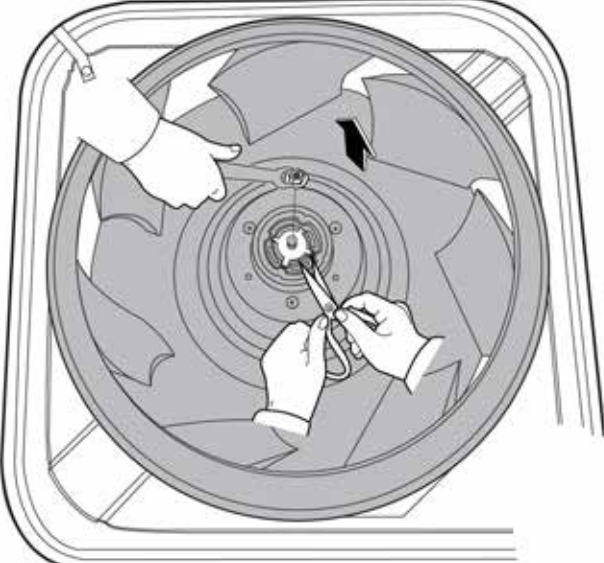
Procedure	Illustration
<p>1) Remove 4 screws of water collector then remove it.(see CJ_MCA_01 1)</p>	 <p>CJ_MCA_011</p>
<p>2) Remove the nut of the fan and then pull up the fan.(see CJ_MCA_0 12)</p>	 <p>CJ_MCA_012</p>

Note: This section is for reference only. Actual unit appearance may vary.

Procedure

3) Remove the nuts and remove the fan motor(see CJ_MCA_0 13)

Illustration

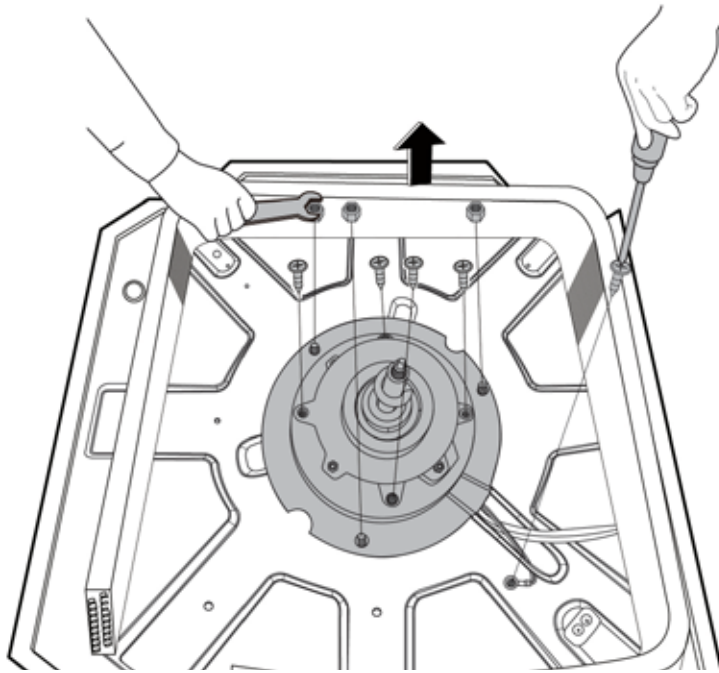

CJ_MCA_013

Note: This section is for reference only. Actual unit appearance may vary.

4. Water Pump

Note: Remove the front panel, electrical parts and water collector (refer to 1,2 &3) before disassembling water pump.

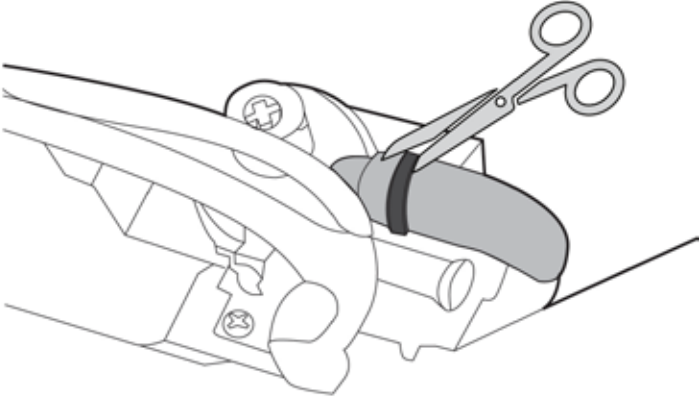
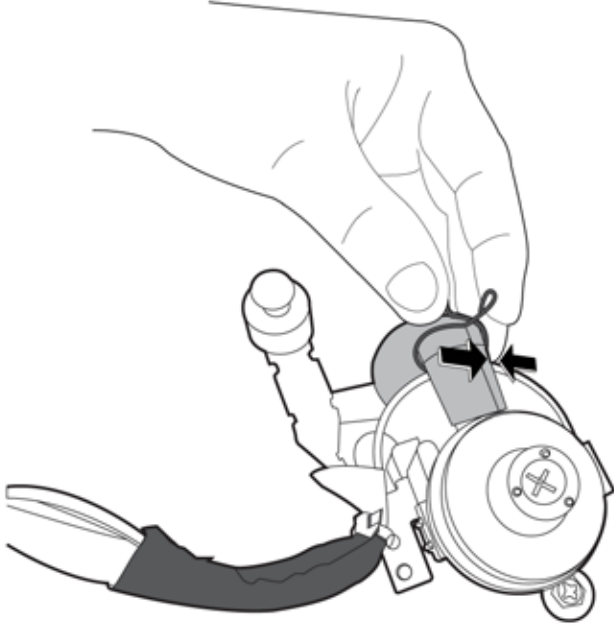
Procedure	Illustration
1) Take off the fasten belt of the water pump. (see CJ_MCA_016)	 <p data-bbox="928 936 1082 967">CJ_MCA_016</p>
2) Pinch the metal wire in the direction shown in the figure to release it. (see CJ_MCA_017)	 <p data-bbox="928 1836 1082 1868">CJ_MCA_017</p>

Note: This section is for reference only. Actual unit appearance may vary.

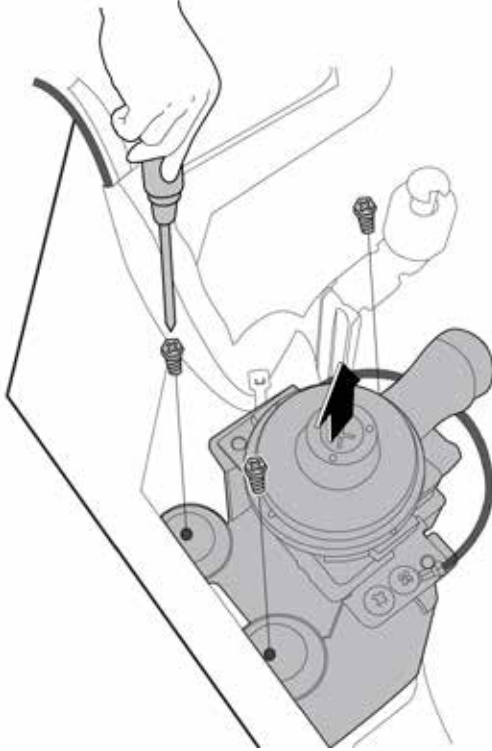
Procedure	Illustration
<p>3) Remove 3 screws and then remove the water pump. (see CJ_MCA_018)</p>	 <p>CJ_MCA_018</p>

5. Evaporator

Note: Remove the front panel, electrical parts and fan (refer to 1,2 &3) before disassembling evaporator.

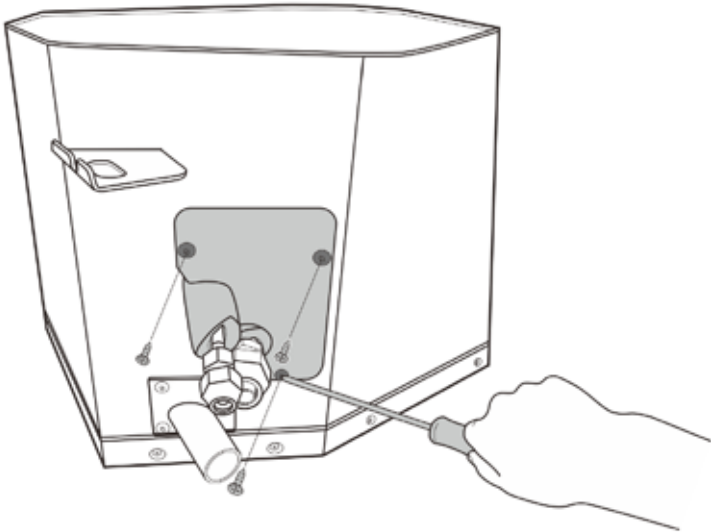
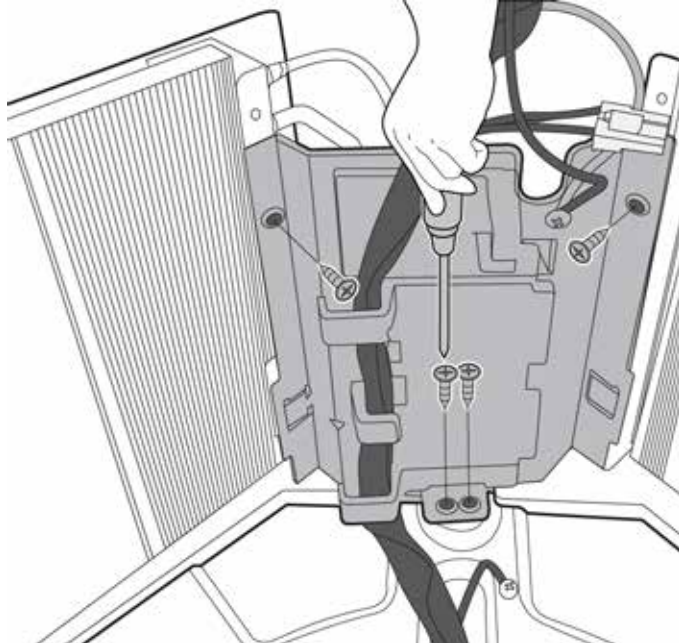
Procedure	Illustration
<p>1) Remove 3 screws of pipe clamp board assembly then remove it.(see CJ_MCA_01 9)</p>	 <p>CJ_MCA_019</p>
<p>2) Remove 4 screws of evaporator fixing board then remove it.(see CJ_MCA_0 20)</p>	 <p>CJ_MCA_020</p>

Note: This section is for reference only. Actual unit appearance may vary.

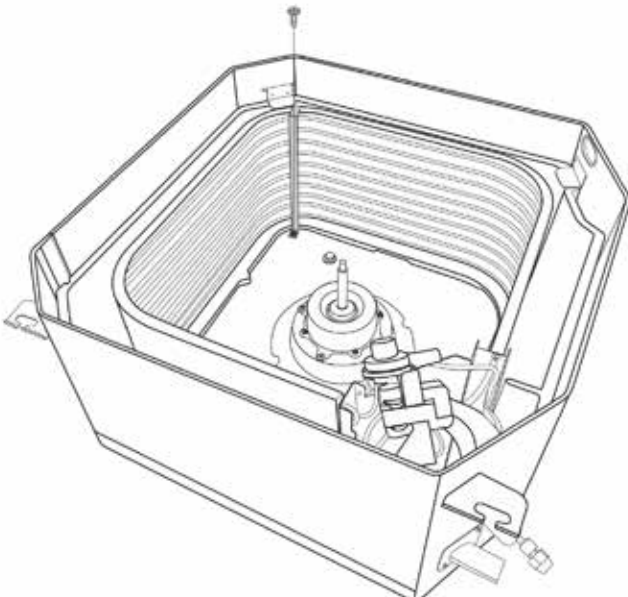
Procedure	Illustration
<p>3) Remove 1 screw of evaporator fixing hook and remove it. (see CJ_MCA_02 1)</p>	 <p data-bbox="925 1064 1077 1097">CJ_MCA_021</p>

Note: This section is for reference only. Actual unit appearance may vary.